

Semantic Modeling

- 'role' is a qualifier attribute it means that a Party plays a role in relation to a Real Estate
- E.g. :
  - 'Company OLDA' is a *Renter* of 'building 44T1'
  - 'BankY' is the *Owner* of 'building 44T1'
  - 'SecureCompany' is the *Security Officer* of 'building 44T1'

- Role is an enumeration data type with values such as:
  - Renter
  - Owner
  - Security Officer
  - Investor
  - Cleaning Company
  - Telephone Company
  - Electricity Company
  - Etc.

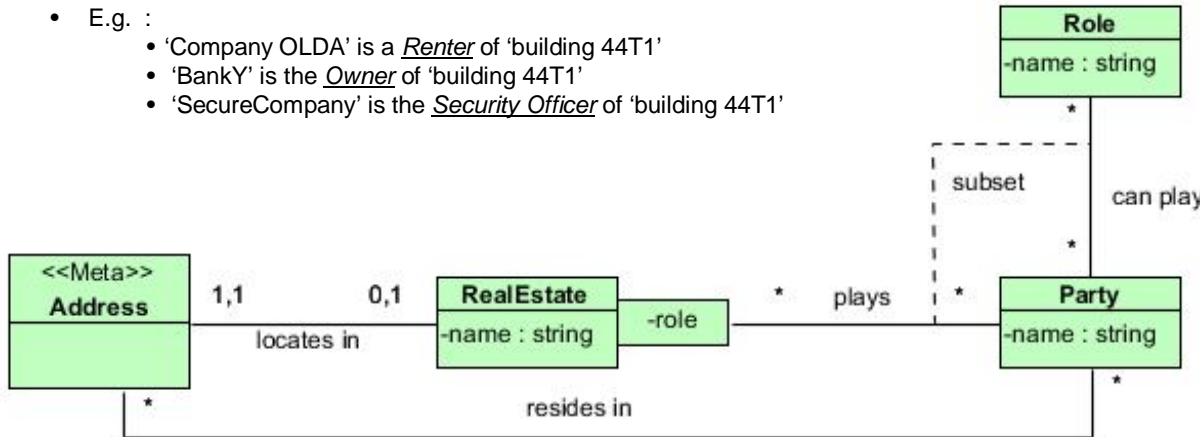

Logical Modeling

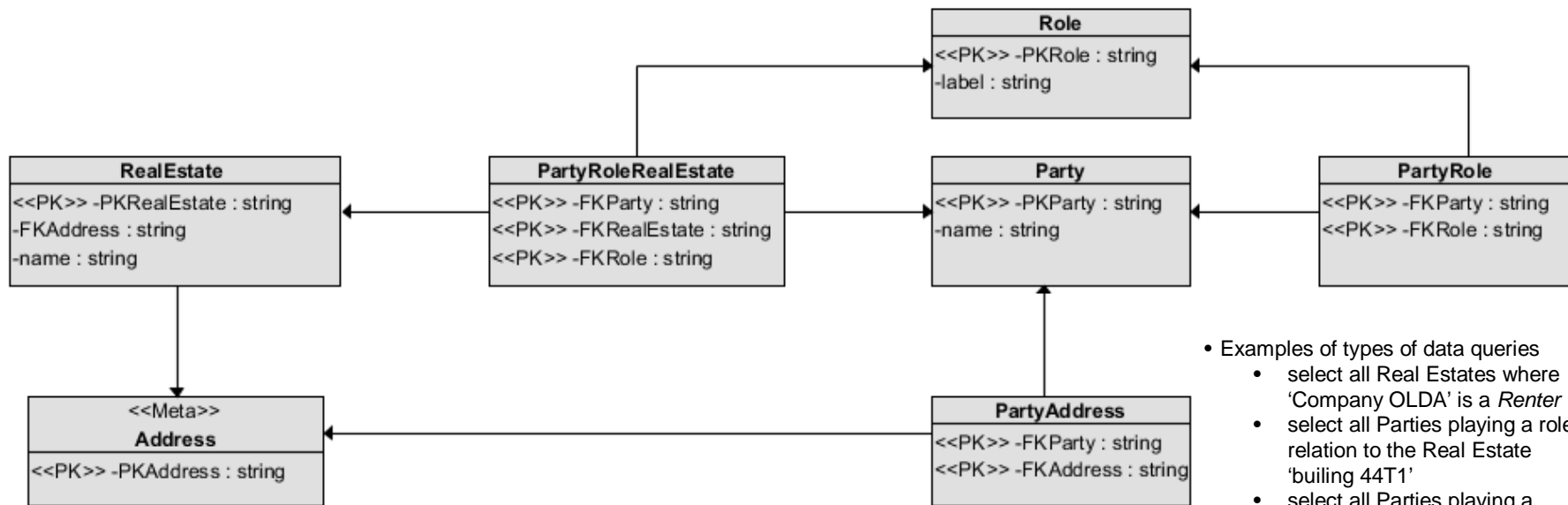

- Examples of types of data queries
  - select all Real Estates where 'Company OLDA' is a *Renter*
  - select all Parties playing a role in relation to the Real Estate 'building 44T1'
  - select all Parties playing a *Security Officer* role